

# Bio 7

Scanjet tank cleaning equipment



## KEY FEATURES

- Rotating spray
- 360 degree spiral cleaning
- Ideal for medium and large tanks
- Low pressure
- Low volume

Bio 7 is a rotating spray nozzle/head that is driven by the cleaning fluid and is a very effective CIP alternative compared to traditional static spray balls. The fan like cleaning action provides improved coverage at low pressure whilst reducing the usage of cleaning media to a minimum.

### Quality Control, Compliances & Certifications

Bio 7 is manufactured in AISI 316/316L and can be polished according to specification. 3.1 certificates can be quoted on request.

### Typical applications for the Bio 7

- Medium yeast tanks
- Dairy and beverage transportation
- Large barrels
- Large ducting
- Large beverage tanks
- Mixing vessels
- Dairy processes



BIO7\_TCT\_2016\_01\_14



**Distributed and Serviced by...**  
Tank Cleaning Technologies, Inc.  
15200 Middlebrook Drive; Suite E  
Houston, Texas 77058 - USA  
Phone: +1 281.480.4041  
Fax: +1 713 516.5883  
Email: [sales@tankcleantech.com](mailto:sales@tankcleantech.com)

[www.tankcleantech.com](http://www.tankcleantech.com)

Stocking Locations in USA, Canada and Mexico



## Technical performance

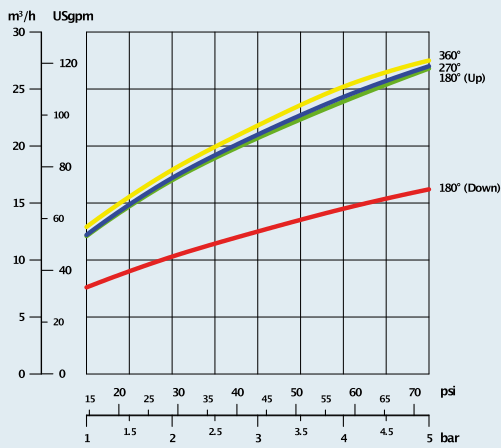

Pressure/Flow (BSP)

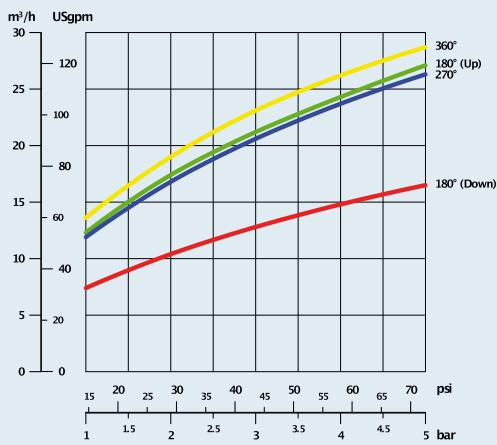

Pressure/Flow (Clip)

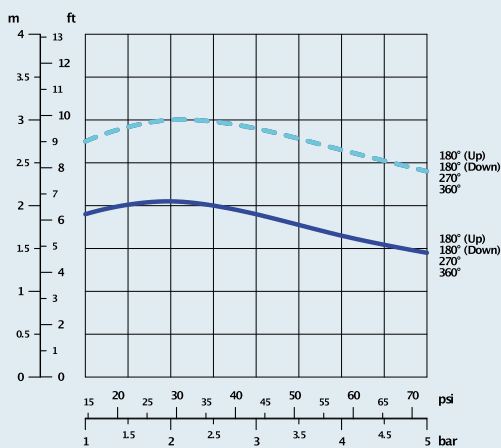

Cleaning radius

## Dimensions

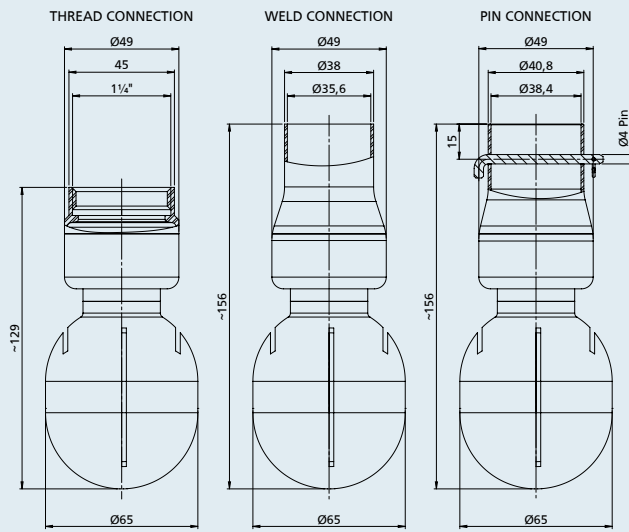

## Spray pattern

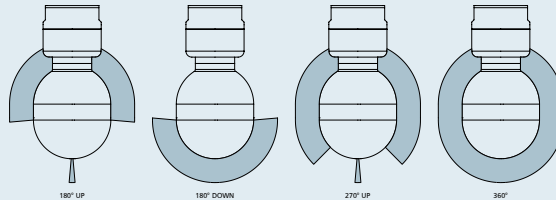

## Specifications

Flow	7,5-29,5 m³/h
Inlet pressure	1-5 bar
Max pressure	5 bar
Recommended pressure	2-3 bar
Max working temperature	95°C
Max ambient temperature	140°C
Weight	500 g
Connections	1 1/4" BSP or NPT, weld-on or pin
Material	Balls in AISI 316 and PTFE, all other parts in AISI 316L
Lubrication	Cleaning media

BIO7\_TCT\_2016\_01\_14



**Distributed and Serviced by...**  
 Tank Cleaning Technologies, Inc.  
 15200 Middlebrook Drive, Suite E  
 Houston, Texas 77058 - USA  
 Phone: +1 281.480.4041  
 Fax: +1 713 516.5883  
 Email: sales@tankcleantech.com

[www.tankcleantech.com](http://www.tankcleantech.com)

Stocking Locations in USA, Canada and Mexico