

SC 360APR

Scanjet Marine Protection System



Scanjet SC 360APR is a high capacity Anti-pirate water cannon for boarding denial. The fixed installed or removable, self operating, multi nozzle machine is driven by the water flow. The Anti-pirate water cannons consist of three main parts; an Anti-pirate water cannon gun unit, a turbine powered drive unit and a mounting rail bracket.

The pump capacity, construction and requirements of the vessel are the design criteria, which have to be evaluated prior to installation. The SC 360APR can be powered by existing pumps on board the vessel. It can be installed either as permanent or as portable units to give the vessel the opportunity to optimise its system and budget.

The horizontal position of the nozzles can when installed be adjusted for each machine. It is possible to optimise the angle to the hull as needs may vary at different positions along the vessels length and due to shape of the hull. The SC 360APR requires no chemicals or steam additives - it has no environmental impact.

By starting the pumps, the SC 360APR starts automatically. The nozzles rotate 360° in a continuous movement. To optimise the downward pressure of the water, the SC 360APR restricts the water from being projected upwards. This is clearly marked for easy installation. The SC 360APR is developed to protect crew, vessel and cargo. It is a non lethal, passive way of protecting the ship without provoking the attacker.



Distributed and Serviced by...
Tank Cleaning Technologies, Inc.
15200 Middlebrook Drive; Suite E
Houston, Texas 77058 - USA
Phone: +1 281.480.4041
Fax: +1 713 516.5883
Email: sales@tankcleantech.com

www.tankcleantech.com

Stocking Locations in USA, Canada and Mexico

KEY FEATURES

SC 360APR

- Protect your crew and ship
- No need for manual operation
- Easy mounting without hot work
- Individually adjusted machine length and horizontal position
- Removable after use
- Grease lubricated drive unit
- Adjustable rotating speed
- 180° optimised down operation

SC 360APR



*Scanjet SC 360APR
Based on existing and well proven Scanjet tank cleaning machine technology.*

*Patent pending
PCT/SE2010/050370
Priority date 2009-04-08
Patent pending 1050695-4
Priority date 2010-06-24*



Technical performance

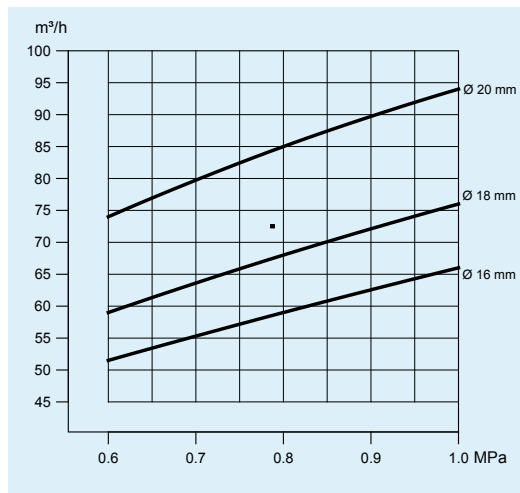

Water flow for selection of different nozzle sizes at specific inlet pressure.

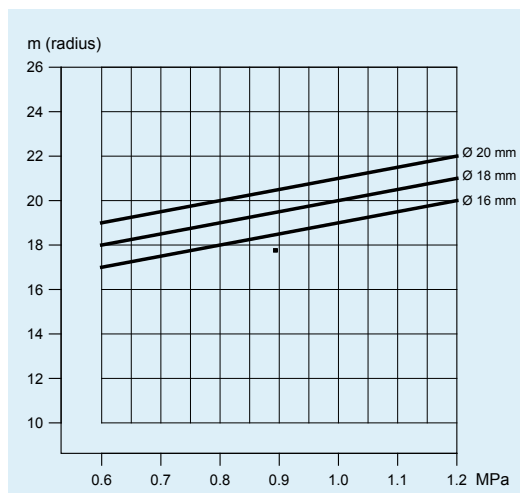

Jet length for selection of different nozzle sizes at specific inlet pressure.



SC 360APR mounted on handrail.

Dimensions

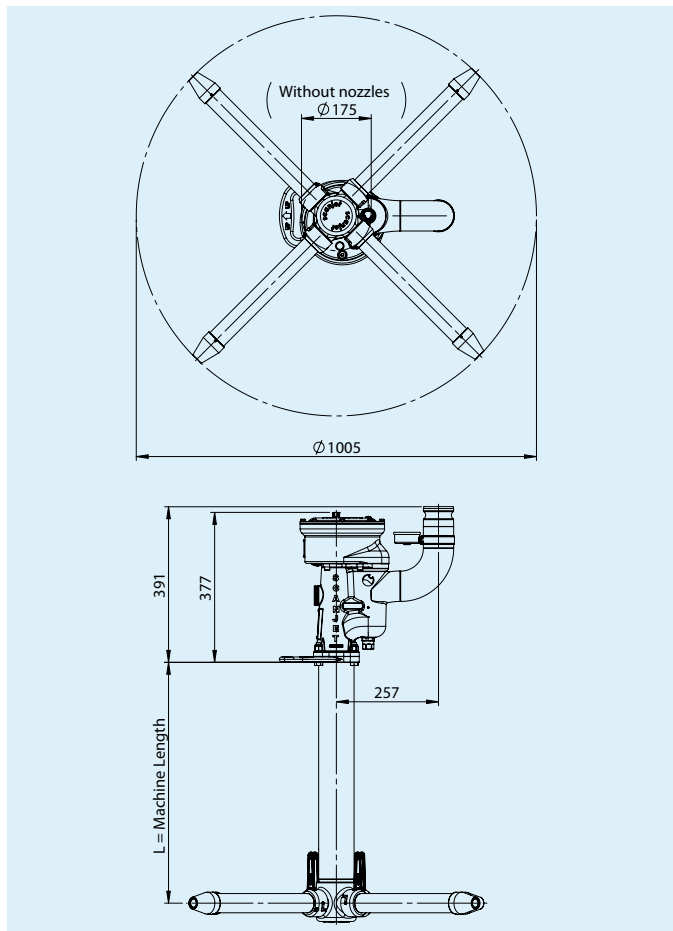

Specifications

Flow	50-100 m ³ /h
Inlet pressure	0,3-1,2 MPa
Recommended pressure	0,5-0,8 MPa
Max temperature	95°C
Rotation speed	3-6 rpm
Material	
Inlet housing and main pipe	AISI 316 / SS2348 / WST 1.4404
Weight (approx)	
Machine, L=0,9 m	31 kg
Bracket	14 kg
Packing box size and weight	
1,6x0,4,0,5 m	7 kg
Total gross weight	62 kg
Other part	Makers' standard
Service space	Min 500 mm radius from centre of machine (at rail bracket) for handling and service.

Adjustable positions

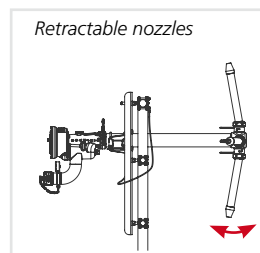
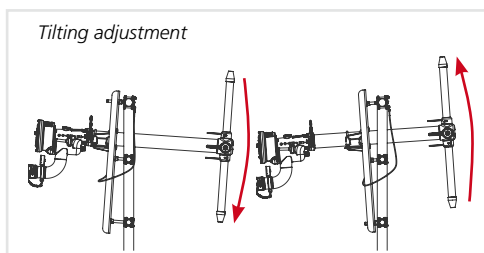
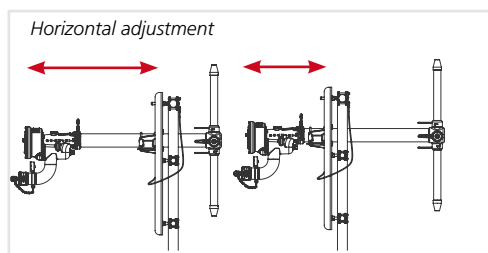

Distributed and Serviced by...
 Tank Cleaning Technologies, Inc.
 15200 Middlebrook Drive; Suite E
 Houston, Texas 77058 - USA
 Phone: +1 281.480.4041
 Fax: +1 713 516.5883
 Email: sales@tankcleantech.com

www.tankcleantech.com

Stocking Locations in USA, Canada and Mexico

We reserve the right to changes without prior notice. Issue 07-10.11

SC360APR_TCT_2017_02_24