

SC 30A

Scanjet tank cleaning equipment



Product summary

The SC 30A is a single nozzle tank cleaning machine especially developed for sector cleaning tanks/cisterns/vessels in hazardous ATEX classified areas.

SC 30A gives the user a possibility to optimize the cleaning, with minimal use of time, energy and cleaning media.

SC 30A consists of two main parts; one washing unit that is fixed installed in the tank and one portable air driven drive unit SC 100, SC 100 PW or SC 180 for operation. The drive unit can be exchanged or removed without exposing the tank to the outside atmosphere.

As option the SC 30A can be provided with a free selection of single nozzle levels giving a tailor-made installation for each specific need.

Quality Control, Compliances & Certifications

SC 30A is produced in accordance with ISO 9001 Quality Standards and our certificate of conformity and accreditation is available on request.

Additionally, the SC 30A conforms to United States ASME standards for construction and European, CE and ATEX standards for design, construction and safety.

Typical applications for the SC 30A:

- Crude oil storage tanks
- Large process vessels and fermenters
- Large silos and dryers
- Large reactors
- Large Uni-Tanks

	SC 100	SC 100PW	SC 180
Air pressure	0,5 - 0,7 MPa	0,5 - 0,7 MPa	0,5 - 0,7 MPa
Air consumption	250 l/min	250 l/min	450 l/min
RPM	0,5 - 2,0	1,0 - 5,0	0,5 - 5,0
Elevation	3°	7,2°	1,5°, 3°, 4,5°, 30° PW
Vertical sector clean	0 - 180°	0 - 180°	0 - 200°
Horizontal sector clean	-	-	0 - 400°

KEY FEATURES

SC 30A

- ATEX
- Programmable sector cleaning
- Rugged construction
- External drive
- High jet impact
- High capacity

SC 30A



1034_SC30A_2016_01_14

Technical performance

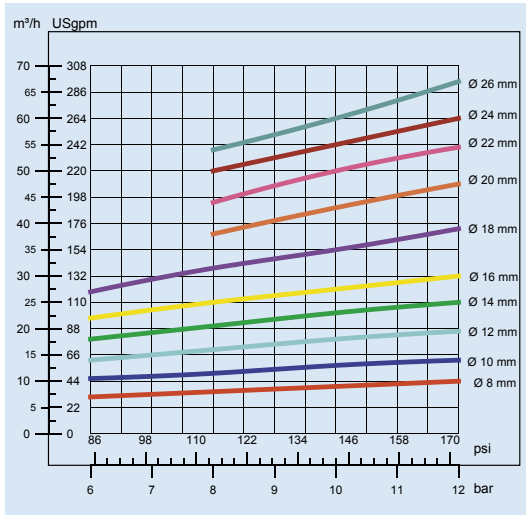

Pressure/Flow

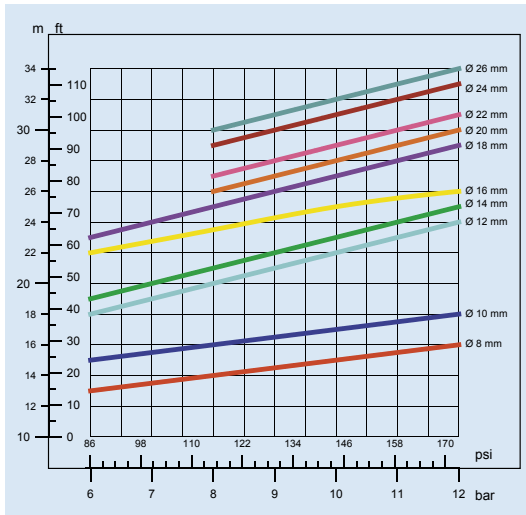

Jet length

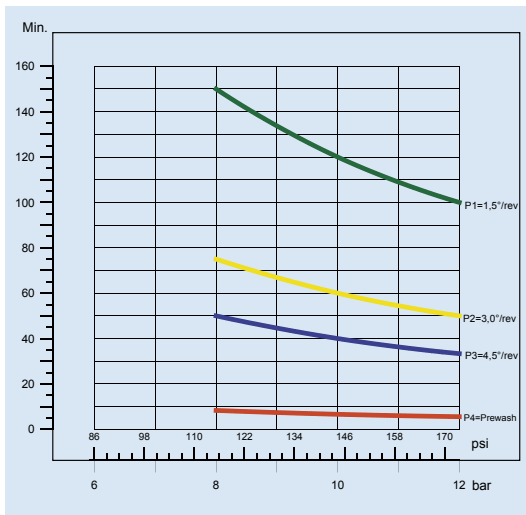

Pattern time

Dimensions

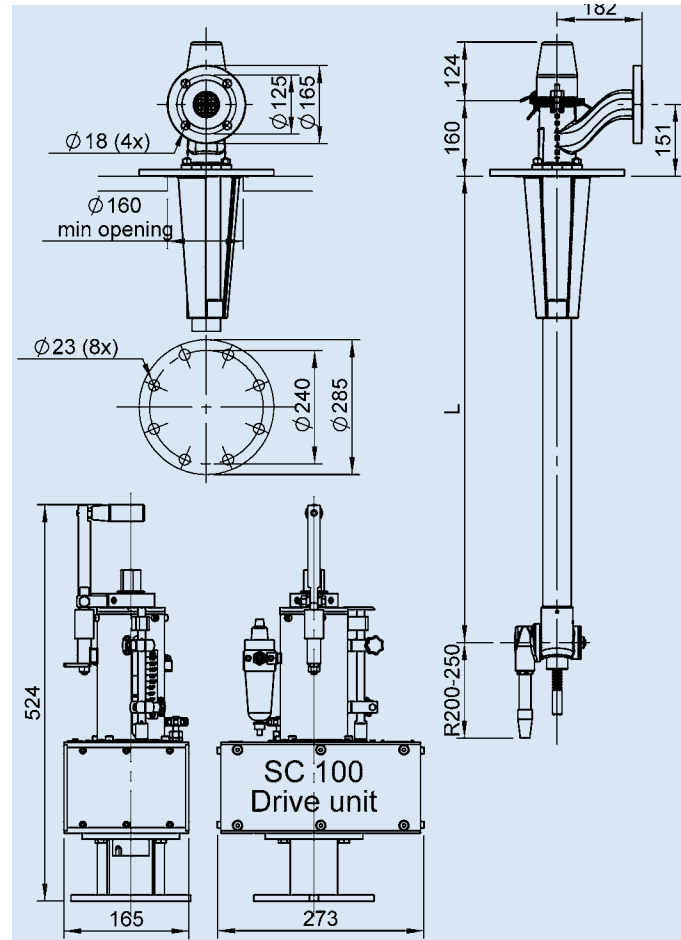

Specifications

Flow	5-65 m³/h
Inlet pressure	6-12 bar
Max pressure	14 bar
Recommended pressure	8 bar
Max temperature	95°C
Standard length	1500 mm
Weight	44 kg
Per additional meter of main pipe	10 kg
Tank connection	PN16 DN150
Inlet connection	PN16 DN50
Materials	AISI 316, PTFE, Viton
Lubrication	Cleaning Media



Distributed and Serviced by...
 Tank Cleaning Technologies, Inc.
 15200 Middlebrook Drive, Suite E
 Houston, Texas 77058 - USA
 Phone: +1 281.480.4041
 Fax: +1 713 516.5883
 Email: sales@tankcleantech.com

www.tankcleantech.com

Stocking Locations in USA, Canada and Mexico



www.scanjet.se