

SC 90A

Scanjet tank cleaning equipment



KEY FEATURES

- ATEX
- Programmable sector cleaning
- Rugged construction
- External drive
- High jet impact
- High capacity

The SC 90A is a single nozzle tank cleaning machine especially developed for sector cleaning tanks/cisterns/vessels in hazardous ATEX classified areas. It gives the user a possibility to optimize the cleaning, with minimal use of time, energy and cleaning media.

SC 90A consists of two main parts; one washing unit that is fixed installed in the tank and one portable air driven drive unit SC 150 for operation. The drive units can be exchanged or removed without exposing the tank to the outside atmosphere. It is the product of choice when long jet-lengths and/or a high level of jet impact is required.

Quality Control, Compliances & Certifications

The SC 90A is produced in accordance with ISO 9001 Quality Standards and our certificate of conformity and accreditation is available on request. Additionally, the SC 90A conforms to United States ASME standards for construction and European, CE and ATEX standards for design, construction and safety.

Typical applications for the SC 90A:

- Crude oil storage tanks
- Large process vessels and fermenters
- Large silos and dryers
- Large reactors
- Large Uni-Tanks

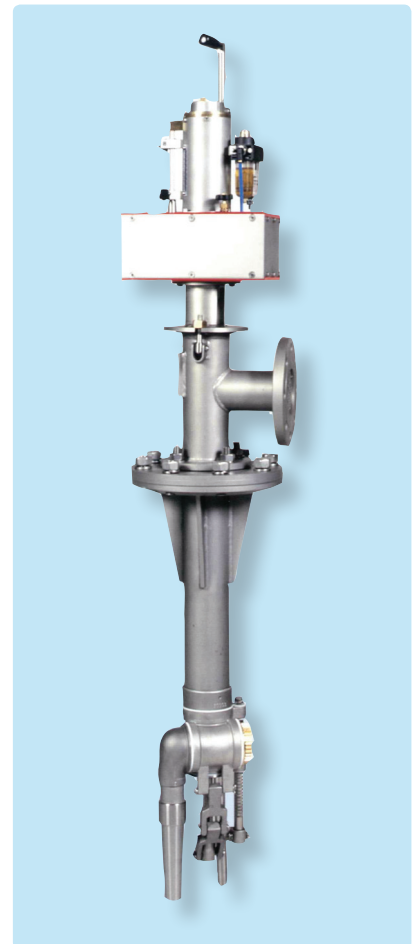

SC90A_TCT_2016_01_14



Distributed and Serviced by...
Tank Cleaning Technologies, Inc.
15200 Middlebrook Drive; Suite E
Houston, Texas 77058 - USA
Phone: +1 281.480.4041
Fax: +1 713 516.5883
Email: sales@tankcleantech.com

www.tankcleantech.com

Stocking Locations in USA, Canada and Mexico



Technical performance

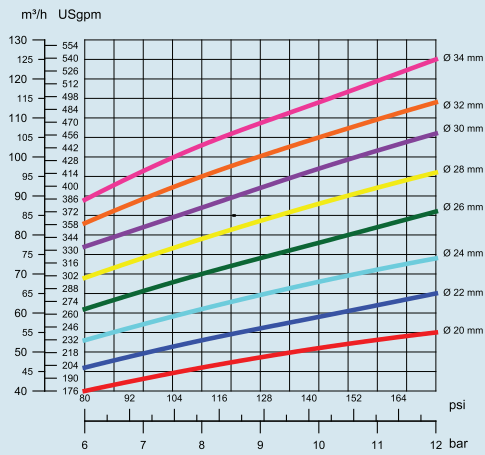

Pressure/Flow

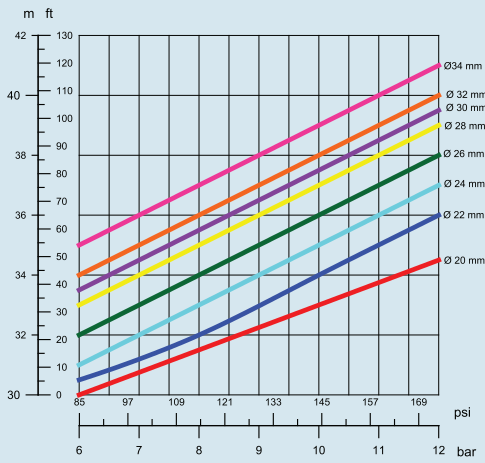

Jet length

Dimensions

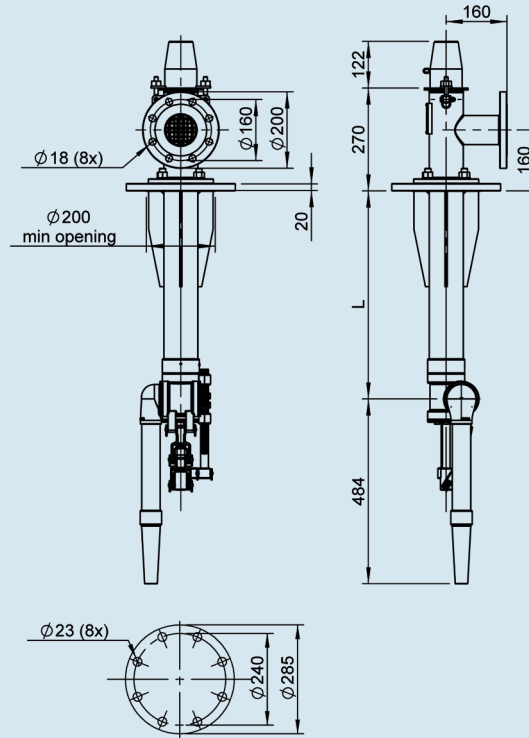

SC 150



SC 150PW

Air pressure	0,5 - 0,7 MPa	0,5 - 0,7 MPa
Air consumption	250 l/min	250 l/min
RPM	0,5 - 2,0	1,0 - 5,0
Elevation per rotation	2°	5°
Sector clean	0 - 180°	0 - 180°

Specifications

Flow	40-106 m³/h
Inlet pressure	6-12 bar
Max pressure	14 bar
Recommended pressure	8 bar
Max temperature	95°C
Rotation speed	0,5-5 rpm
Standard length	1500 mm
Weight	75 kg
Per additional meter of main pipe	15 kg
Tank connection	PN16 DN150
Inlet connection	PN16 DN80
Materials	AISI 316, PTFE/Viton
Lubrication	Cleaning Media

SC90A_TCT_2016_01_14



Distributed and Serviced by...
 Tank Cleaning Technologies, Inc.
 15200 Middlebrook Drive; Suite E
 Houston, Texas 77058 - USA
 Phone: +1 281.480.4041
 Fax: +1 713 516.5883
 Email: sales@tankcleantech.com

www.tankcleantech.com

Stocking Locations in USA, Canada and Mexico

