

SC 20E-LP

Scanjet tank cleaning equipment



KEY FEATURES

- + Electrical external drive
- + Fixed or portable
- + Bayonet coupling
- + High impact
- + Low volume

The SC 20E-LP is a tank cleaning machine specially developed for the cleaning of small industrial tanks where product residues are hard to remove and cleaning volumes need to be kept to a minimum. The device can either be used on a fixed installed or portable basis and is available in two, three or four nozzle configurations. The external drive is an electrical motor being 230V(AC) although other alternatives are available on request.

Tank connection is as standard a universal flange making it easy to remove the machine from the tank without the need for tools.

Quality Control, Compliances & Certifications

The SC 20E-LP is produced in accordance with ISO 9001 Quality Standards and our certificate of conformity and accreditation is available on request.

Additionally, the SC 20E-LP conforms to United States ASME standards for construction and others are available upon request.

Typical applications

- + Paints and coatings process vessels
- + Solvent tanks
- + Totes and IBC's
- + Heavy duty process vessels



SC_20E-LP_TCT_2016_01_14



Distributed and Serviced by...
Tank Cleaning Technologies, Inc.
15200 Middlebrook Drive, Suite E
Houston, Texas 77058 - USA
Phone: +1 281.480.4041
Fax: +1 713 516.5883
Email: sales@tankcleantech.com

www.tankcleantech.com

Stocking Locations in USA, Canada and Mexico



Technical performance

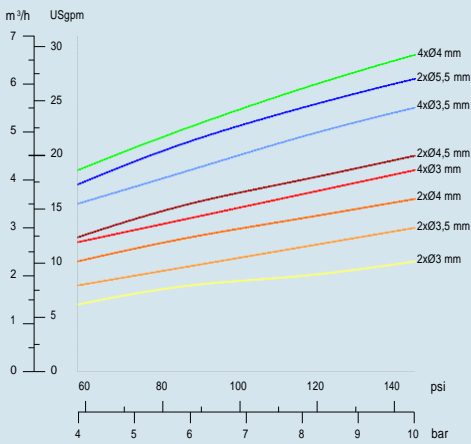

Pressure/Flow Various nozzle configurations are available. Contact your local distributor for details

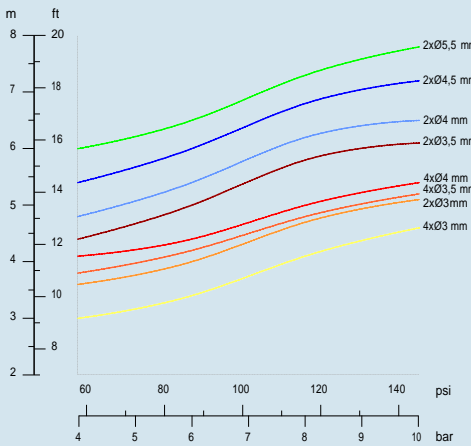

Jet length Various nozzle configurations are available. Contact your local distributor for details

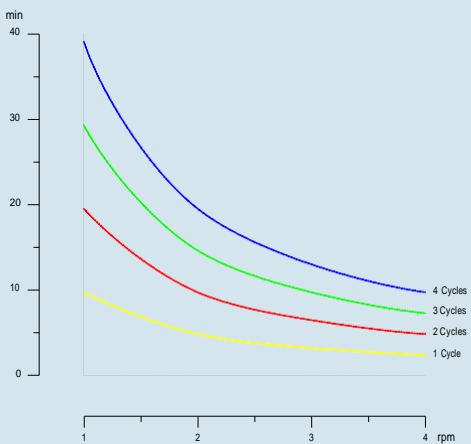

Pattern time

Dimensions

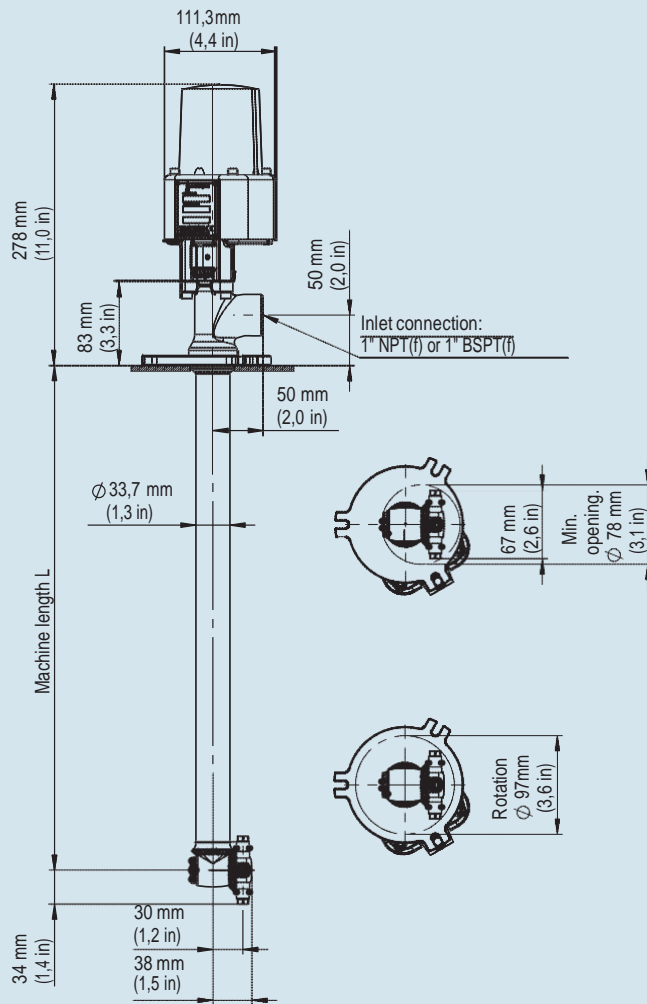

Specifications (Low Pressure)

Flow	1,1 -6,5 m³/h
Inlet pressure	4-10 bar
Max pressure	12 bar
Recommended pressure	5-6 bar
Max temperature	95°C
Rotation speed	1-4 rpm
Full cleaning cycle	12 min
Standard length	0,5 or 1 m
Weight	6,2 kg
Inlet connection	1" BSP/NPT
Tank connection	Universal coupling
Materials	AISI 316, PTFE, PEEK
Lubrication	Cleaning Media

SC_20E-LP_TCT_2016_01_14



Distributed and Serviced by...
 Tank Cleaning Technologies, Inc.
 15200 Middlebrook Drive; Suite E
 Houston, Texas 77058 - USA
 Phone: +1 281.480.4041
 Fax: +1 713 516.5883
 Email: sales@tankcleantech.com

www.tankcleantech.com
 Stocking Locations in USA, Canada and Mexico